

1. A group of students investigate the circuit shown in the figure below.

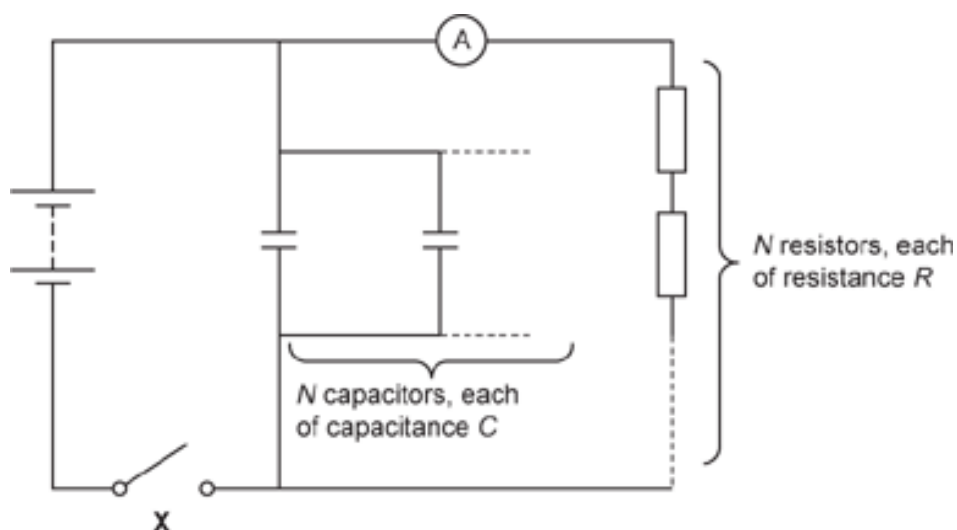

There are N capacitors, each of capacitance C , connected in parallel.

There are N resistors, each of resistance R , connected in series.

Initially, the students close the switch **X**. They then note the reading on the ammeter.

The students then open the switch. They record the time T for the reading on the ammeter to fall to half of its initial value.

The table below shows the students' results.

N	T/s			Mean
	1	2	3	
1	14.7	14.1	14.3
2	50.3	49.6	50.1
3	126.6	126.3	125.2	126.0
4	224.4	224.3	225.9	224.9
5	356.1	354.3	345.6	352.0
6	500.4	512.7	499.5	504.2

Show that $T = (\ln 2)N^2RC$.

2. This question is about lightning.

Sheet lightning occurs when there is an electrical discharge between the upper and lower regions of a thunder cloud.

The upper regions are positive and the lower regions are negative.

The thunder cloud can be modelled as an ideal parallel plate capacitor with circular horizontal plates.

The data for the capacitor comes from the cloud.

Diameter of cloud	24 km
Distance between upper and lower regions	3.2 km
Electric field strength between the regions	$4.0 \times 10^5 \text{ V m}^{-1}$

i. The diagram shows the plates of the model capacitor superimposed on the cloud.

Draw on the diagram to show the electric field lines between capacitor plates.

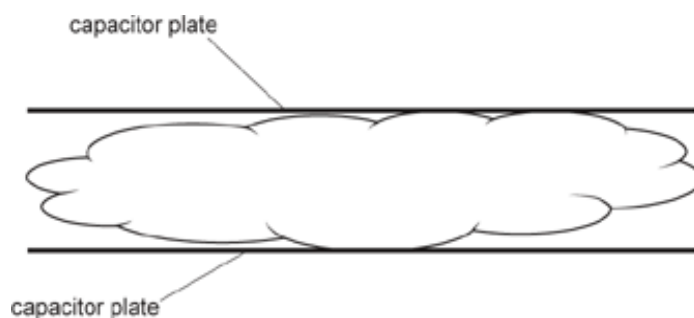

[2]

ii. Suggest why the actual electric field lines of the cloud would differ from what you have drawn.

.....

[1]

iii. Show that the potential difference (p.d.) V between the plates is about $1 \times 10^9 \text{ V}$.

[1]

iv. Calculate the capacitance C of the model capacitor.

Assume the permittivity of the material of the cloud is the same as the permittivity of free space.

$C = \dots\dots\dots \text{ F}$ [2]

- v. Calculate the magnitude of the charge Q on one of the plates of the model capacitor.

$Q = \dots\dots\dots$ C [2]

3. Three capacitors are arranged in a circuit.

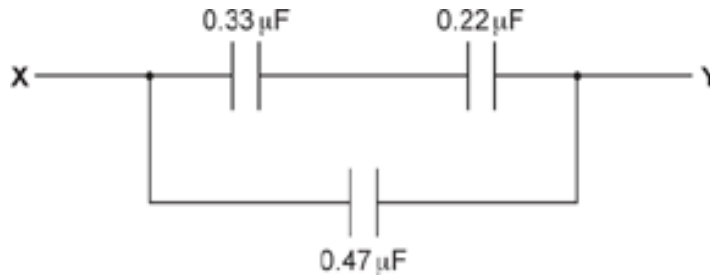

The capacitance of each capacitor is shown.

What is the total capacitance between **X** and **Y**?

- A** $0.25 \mu\text{F}$
B $0.60 \mu\text{F}$
C $1.02 \mu\text{F}$
D $8.0 \mu\text{F}$

Your answer

[1]

4. A student is using a spreadsheet to model the decay of charge on a capacitor.

They are using the equation $\frac{\Delta Q}{\Delta t} = -\frac{Q}{2.5}$

The student chooses a time interval of 0.5s. At time $t = 0.0\text{s}$ the charge on the capacitor is $600 \mu\text{C}$.

Part of the modelling spreadsheet is shown below.

t/s	Charge Q left on capacitor after time $t/\mu\text{C}$	Charge ΔQ decaying in the next $0.5 \text{ s}/\mu\text{C}$
0.0	600	120
0.5	480	
1.0		
1.5		
2.0		

What is the charge on the capacitor at $t = 1.5 \text{ s}$?

- A 130 μC
- B 240 μC
- C 246 μC
- D 307 μC

Your answer

[1]

5(a). Large power stations generate an electrical power of about 1 GW.

Current methods of energy production that use nuclear fusion are unable to produce enough energy for large-scale energy production. A proposed method of controlling nuclear fusion is inertial confinement fusion (ICF). ICF uses a large number of powerful lasers to create the high temperatures required for nuclear fusion to occur.

One ICF experiment uses a network of capacitors to store the energy needed to power the lasers. When the network is fully charged:

- potential difference across the network = 24 kV
- total energy stored in the network = 400 MJ

i. Calculate the total capacitance, C , of the network.

$C = \dots\dots\dots\text{F}$ [2]

ii. Explain why the individual capacitors in the network should be connected in parallel in order to produce this total capacitance.

----- [1]

(b). The total stored energy must be released in a time of less than 1 millisecond.

Explain, using a calculation, why the lasers are powered by the network of capacitors instead of being connected directly to the mains electricity supply.

----- [2]

6(a). In an experiment a circuit is set up so that a capacitor with a resistor in series can be charged and at some later time discharged through the same resistor without changing the positions of the components. This process can be repeated.

The supply has a potential difference (p.d.) 6.0 V d.c.

The capacitor has capacitance 1.0 μF .

The resistor has resistance 10 k Ω .

A voltmeter is used to measure the p.d. across the capacitor.

Draw a circuit diagram for this experiment.

[2]

(b). Calculate the charge Q stored on the capacitor when it is fully charged.

$Q = \dots\dots\dots\text{C}$ [1]

(c). Use a calculation to explain why it will not be possible to measure the variation of p.d. across the capacitor with time, using a stopwatch.

[4]

(d). State how this experiment can be modified to measure the variation of p.d. across the capacitor with time as the capacitor charges.

[1]

(e). The capacitor was completely charged and then discharged to 4.12 V.

i. Calculate the time t required for the p.d. across the capacitor to reach 4.12 V when discharging.

$t = \dots\dots\dots\text{s}$ [2]

- ii. Calculate the average rate at which energy is lost by the capacitor as it discharges from 6.0 V to 4.12 V.

average rate at which energy is lost = J s⁻¹ [3]

7(a).

Define the **time constant** of a circuit containing a capacitor of capacitance C and a resistor of resistance R .

[1]

- (b). The capacitor circuit shown in **Fig. 6.1** can be used to smooth oscillating electrical signals.

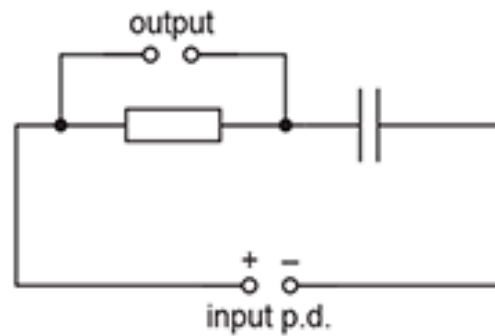

Fig. 6.1

- i. **Fig. 6.2** shows the input signal of potential difference (p.d.) V against time t .

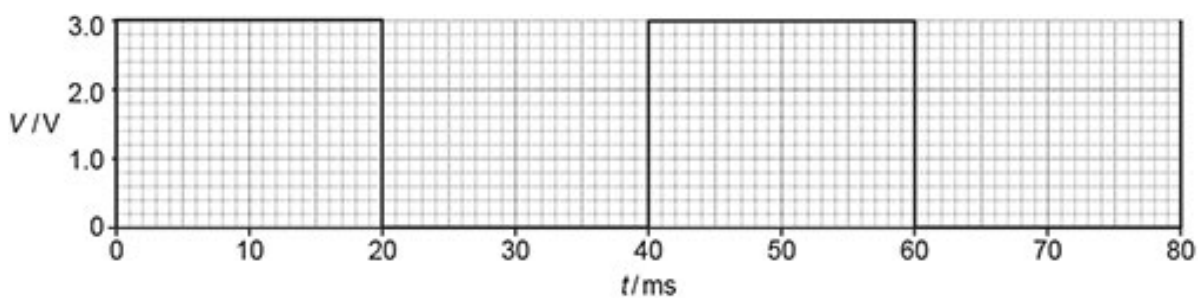

Fig. 6.2

Calculate the frequency f of this input signal.

$f = \dots\dots\dots$ Hz [2]

- ii. **Fig. 6.3** shows the variation of the charge Q on the positive plate of the capacitor with time t .

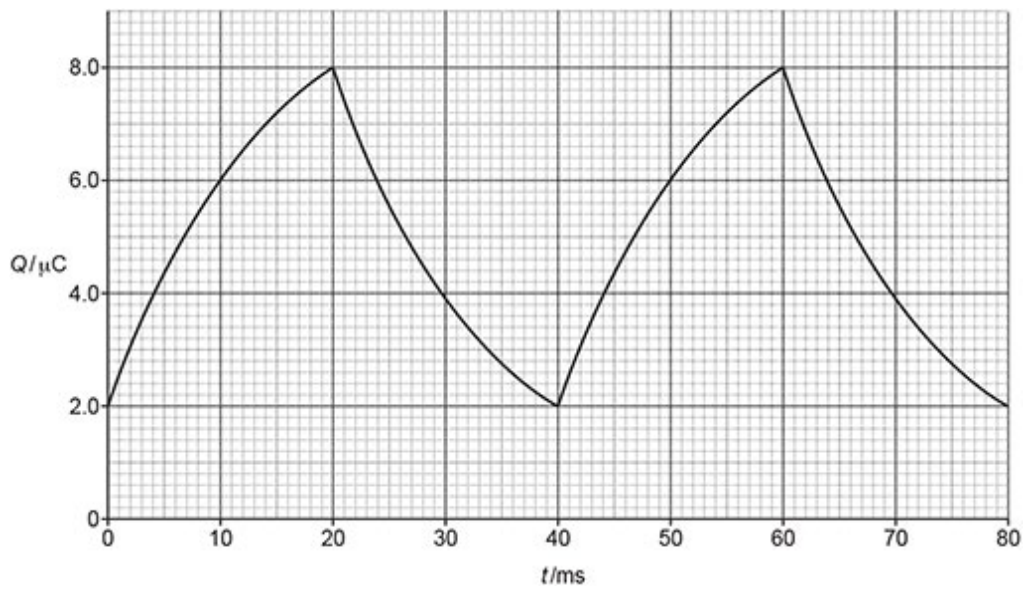

Fig. 6.3

Use a discharging section of the graph in **Fig. 6.3** to determine the time constant of the circuit. Give your answer in ms.

time constant = ms [2]

- iii. By drawing a suitable tangent to the graph in **Fig. 6.3**, calculate the maximum current in the resistor.

maximum current =A [2]

- iv. On **Fig. 6.4** below, sketch the variation of the current I in the resistor with time t . Include an appropriate label and scale on the vertical axis.

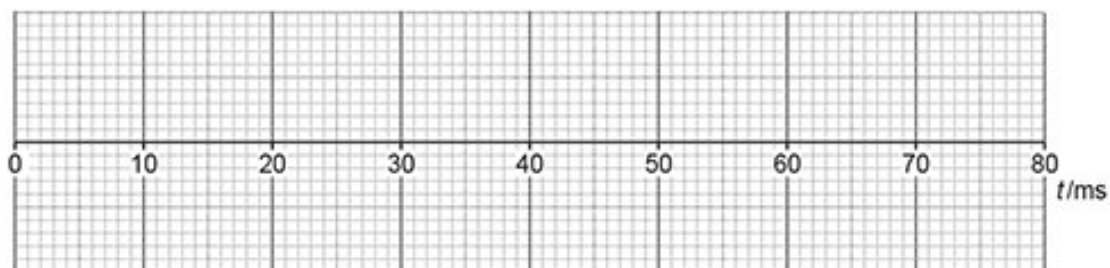
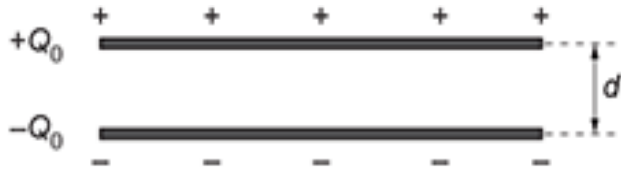

Fig. 6.4

[3]

8(a).

The diagram below shows a simple capacitor.



The capacitor consists of two horizontal metal plates in a vacuum. The magnitude of the charge on each plate is Q_0 . The potential difference (p.d.) between the plates is V_0 . The capacitor plates have capacitance C_0 . The separation between the plates is d . The energy stored by the capacitor is E_0 .

The top plate is moved vertically upwards. The new separation between the plates is $2d$.

The charge on each plate remains the **same**.

The energy stored by the capacitor **increases**.

i. Determine the new:

1 capacitance in terms of C_0

capacitance = C_0 [1]

2 p.d. between the plates in terms of V_0

p.d. = V_0 [1]

3 energy stored in terms of E_0 .

energy = E_0 [1]

ii. Explain, in terms of forces between the plates, why the energy stored increases.

[1]

(b). A student discharges a capacitor of capacitance C through a variable resistor of resistance R using the arrangement below.

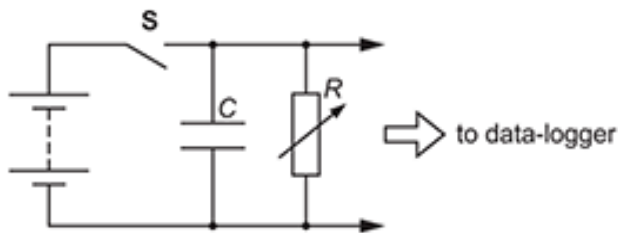

The capacitor is made from two parallel metal plates separated by a sheet of paper of thickness 8.0×10^{-5} m. The area of overlap between the plates is 3.1×10^{-2} m².

The capacitor is charged fully by closing switch **S**. At time $t = 0$, **S** is opened and the capacitor discharges through the resistor. After $t = T$, the potential difference across the capacitor is halved. The student repeats this for several values of R .

- i. The student decides to plot T against R to obtain a straight-line graph.

Show that the line has gradient = $C \ln 2$.

[2]

- ii. The data points plotted by the student are shown below.

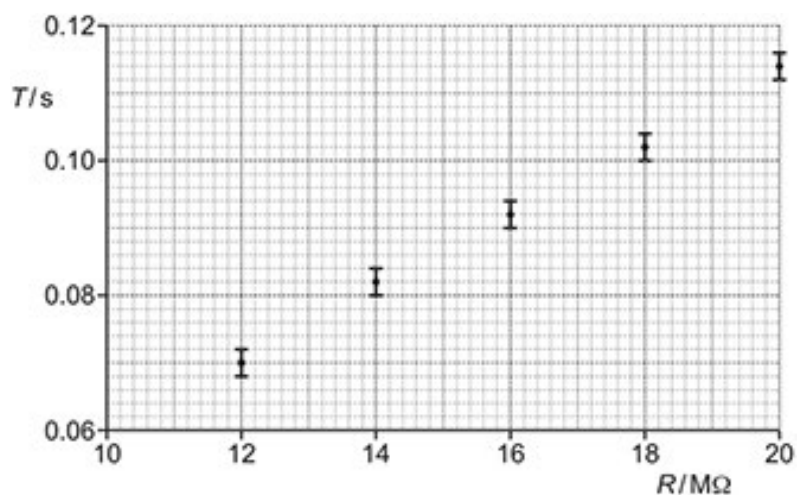

Draw a best-fit straight line through the data points and use the gradient of this line to determine C .

1

$C = \dots\dots\dots$ F [3]

Use your answer in (ii)1 to calculate the permittivity ϵ of the paper.

2

$\epsilon = \dots\dots\dots$ F m⁻¹ [2]

END OF QUESTION PAPER